



Outdoor Unit	Model of Outdoor Unit		GWH09YD-S6DBA2A/O	
	Outdoor Unit Product Code		CB466W00109	
	Compressor Manufacturer/Trademark		ZHUHAI LANDA COMPRESSOR CO., LTD	
	Compressor Model		QXFT-B123zE170A	
	Compressor Oil		FW68DA	
	Compressor Type		Rotary	
	L.R.A.	A	20	
	Compressor RLA	A	7.9	
	Compressor Power Input	W	1230	
	Overload Protector		/	
	Throttling Method		Electron expansion valve	
	Operation Temp	°C	16~30	
	Ambient Temp (Cooling)	°C	-18~54	
	Ambient Temp (Heating)	°C	-30~24	
	Condenser Form		Aluminum Fin-copper Tube	
	Pipe Diameter	mm	Φ7	
	Rows-fin Gap	mm	2.5-1.4	
	Coil Length (LXD <sub>X</sub> W)	mm	763X57X550	
	Fan Motor Speed	rpm	900	
	Output of Fan Motor	W	30	
	Fan Motor RLA	A	0.24	
	Fan Motor Capacitor	μF	/	
	Air Flow Volume of Outdoor Unit	m <sup>3</sup> /h	2400	
	Fan Type		Axial-flow	
	Fan Diameter	mm	Φ438	
	Defrosting Method		Automatic Defrosting	
	Climate Type		T1	
	Isolation		I	
	Moisture Protection		IPX4	
	Permissible Excessive Operating Pressure for the Discharge Side	MPa	4.3	
	Permissible Excessive Operating Pressure for the Suction Side	MPa	2.5	
	Sound Pressure Level (H/M/L)	dB (A)	53/-/-	
Sound Power Level (H/M/L)	dB (A)	62/-/-		
Dimension (WXHXD)	mm	899X596X378		
Dimension of Carton Box (LXWXH)	mm	945X417X630		
Dimension of Package (LXWXH)	mm	948X420X645		
Net Weight	kg	44.5		
Gross Weight	kg	47.5		
Refrigerant		R32		
Refrigerant Charge	kg	1		
Connection Pipe	Length	m	5	
	Gas Additional Charge	g/m	16	
	Outer Diameter Liquid Pipe	mm	Φ6	
	Outer Diameter Gas Pipe	mm	Φ9.52	
	Max Distance Height	m	10	
	Max Distance Length	m	15	
Note: The connection pipe applies metric diameter.				

The above data is subject to change without notice; please refer to the nameplate of the unit.



### 3. Outline Dimension Diagram

#### 3.1 Indoor Unit

09/12K

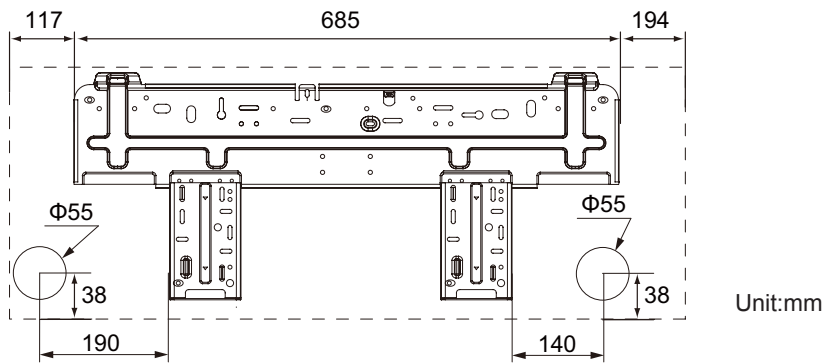
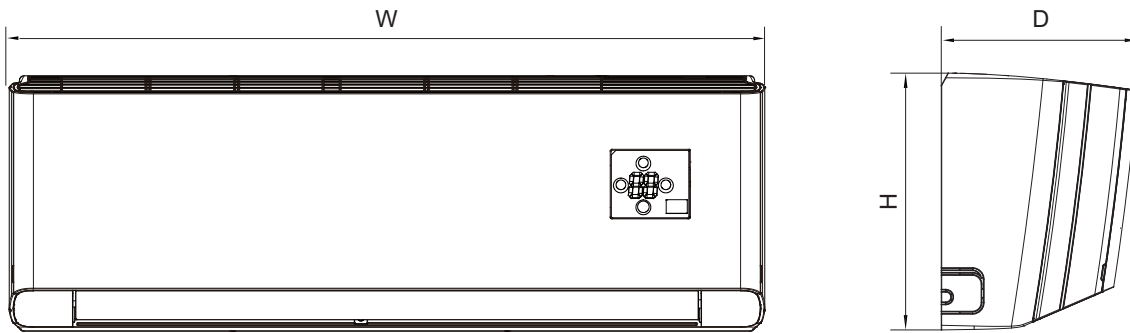

Unit:mm

Model	W	H	D
09K/12K	996	301	225

